

MODEL PAD 55-25

REGULATED DC POWER SUPPLY

INSTRUCTION MANUAL

KIKUSUI ELECTRONICS CORP.

## CONTENTS

	PAGE
1. GENERAL DESCRIPTION .....	1
2. SPECIFICATIONS .....	2
3. OPERATION .....	5
3.1 Front Panel description .....	5
3.2 Precaution .....	8
3.3 How to use sampling terminals .....	9
3.4 Constant-voltage, current characteristics .....	11
3.5 Transient response .....	12
3.6 Single operation .....	12
3.7 Series connection .....	13
3.8 Parallel connection .....	15
3.9 One-control parallel operation .....	17
3.10 Remote control .....	19
3.11 Internal temperature detecting circuit .....	21

\* BLOCK DIAGRAM

\* INPUT CURRENT - OUTPUT VOLTAGE  
CHARACTERISTIC

## 1. GENERAL DESCRIPTION

Kikusui Electronics' Model PAD 55-25 is an all-silicon-transistorized, high reliable, variable regulated DC power supply which has excellent regulation, a low temperature coefficient and fast transient response. It is a universal type usable for either a digital or analog circuit. Since a pre-regulated circuit is built-in, overheating of the entire instrument is suppressed and also Model PAD 55-25 employs a forced air cooling system with a fan. Therefore, the instrument is compact and light-weight in comparison with the conventional instruments although it is of natural cooling type.

The output voltage is adjustable precisely and smoothly over a range of zero to 55V with a 5-turn vernier type variable resistor. The maximum output current is 25A. Model PAD 55-25 can be used as a constant current power supply over a range of 0.5 to 25A. Use of a new circuit technique permits the constant current characteristic to be improved largely, as compared with the conventional type. Model PAD 55-25 is a constant voltage-current automatic crossover type in which the constant output voltage performance and constant current performance are changed over automatically according to load variation. Two LEDs mounted on the front panel indicate the respective operation modes alternately ( constant voltage or constant current ) .

Model PAD 55-25 is not only used in single operation but in series, parallel or one-control parallel operation by which the voltage or current can be expanded. Use of an external resistor also permits the output voltage to be remote-controlled.

## 2. SPECIFICATIONS

AC input	00V±10% AC, 50/60 Hz		
Full load	Approximately	3 kVA	
Dimensions	Case	430W x 319H x 400D mm	
	Maximum	431W x 340H x 400D mm	
Wight	Approximately	50kg	
Ambient temperature	0 ~ 40°C		
Accessories supplied	Short bar .....	1 set	
	Fuse conventional, 30A .....	2	
	Instruction manual .....	1	

### Output

Terminals	Color corded, aligned horizontally; 5-terminals on the rear panel ( -sampling, - , GND , + , +sampling ). Obtainable from the front and rear panels.		
Polarity	Positive or negative		
Floating voltage	±250V maximum		

### Constant voltage characteristics:

Voltage	0 ~ 55V continuously variable with 5-turn variable resistor		
Current	25A		

Ripple noise( 5Hz ~ 1MHz )	500 $\mu$ V rms
Voltage regulation ( when the sampling terminals are used )	
Line regulation	0.005% + 1mV against $\pm 10\%$ variation of line voltage.
Load regulation	0.005% + 2mV against 0 ~ 100% variation of output current.
Transient response ( 10 ~ 100% )	Typical value 100 $\mu$ s
Temperature coefficient	Typical value 100 PPM/ $^{\circ}$ C

Constant current characteristics:

Voltage	0 ~ 55V continuously variable with 5-turn variable resistor
Current	0.5 ~ 25A continuously variable
Ripple noise ( 5Hz ~ 1MHz )	2mA rms
Current regulation	
Line regulation	1mA against $\pm 10\%$ variation of line voltage
Load regulation	3mA against 0 ~ 100% variation of output voltage

Operation	Series operation Parallel operation One-control parallel operation Output voltage remote control
-----------	-----------------------------------------------------------------------------------------------------------

Operation mode indication	Indication by light emitting diode
	Constant voltage ..... C.V.
	Constant current ..... C.C.

Cooling system                      Forced air cooling

Internal temperature detecting circuit

When the internal temperature exceed, this built-in circuit automatically shuts off the output circuit.

Voltmeter	DC 60V	Accuracy ..... class 2.5
Ammeter	DC 30A	Accuracy..... class 2.5

\* Can be installed on 19 in. or 500mm standard rack using brackets.

### 3. OPERATION

#### 3.1 Front panel description ( See Fig. 3-1 and Fig. 3-2 )

- |                              |                                                                                                               |
|------------------------------|---------------------------------------------------------------------------------------------------------------|
| ① POWER switch               | ON/OFF switch for the input power. The upper position is ON. An electromagnetic switch (breaker) is employed. |
| ② Pilot lamp                 | Indicates ON-OFF state of input power. The lamp turns on when the power is ON.                                |
| ③ Constant Voltage indicator | Indicates that Model PAD 55-25 is in the constant voltage mode: ( C.V. )                                      |
| ④ Constant current indicator | Indicates that Model PAD 55-25 is in the constant current mode: ( C.C. )                                      |
| ⑤ VOLTAGE                    | Knob for setting the output voltage. Clockwise rotation increases the output voltage.                         |
| ⑥ CURRENT                    | Knob for setting the output current. Clockwise rotation increases the output current.                         |
| ⑦ Volt meter                 | Indicates the output voltage.<br>DC 60V<br>Accuracy is class 2.5                                              |
| ⑧ Ammeter                    | Indicates the output current.<br>DC 30A<br>Accuracy is class 2.5                                              |

⑨ Output terminals      Aligned in the following order:  
from the left,  
-SAMPLING    ( white )  
-             ( white )  
GND           ( black )  
+             ( red )  
+SAMPLING    ( red )

⑩ Rear terminal plate ( 1 )      Output terminals, sampling terminals,  
GND terminal and input power  
terminals are provided.

⑪ Rear terminal plate ( 2 )      Remote control terminals and one-  
control parallel operation terminals  
are provided.

⑫ Air intake hole



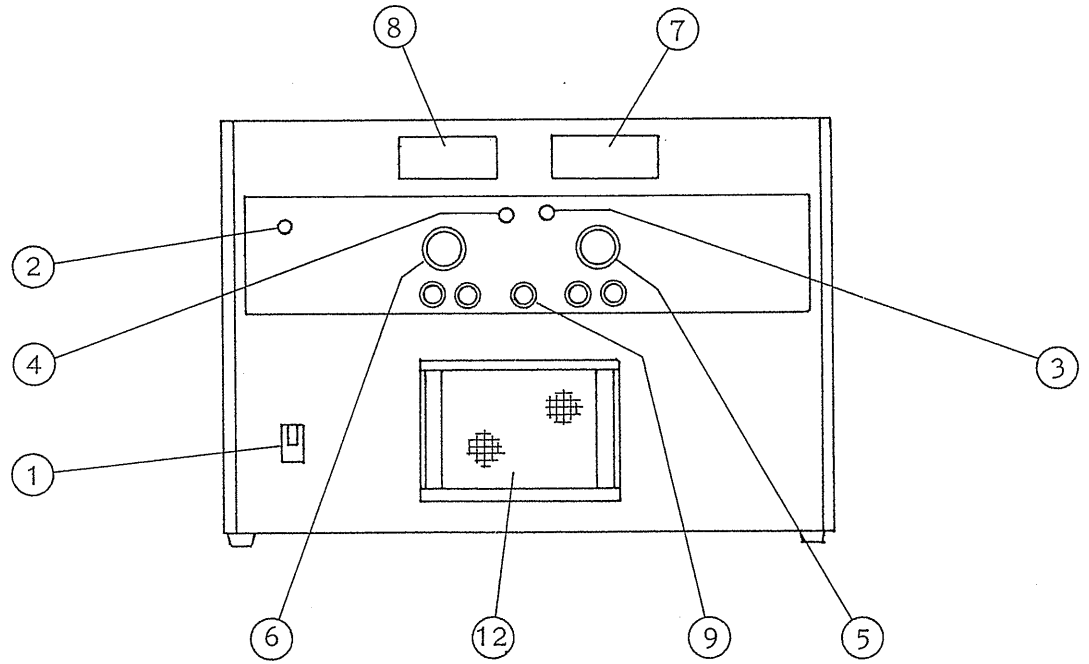

Fig. 3-1 Front panel

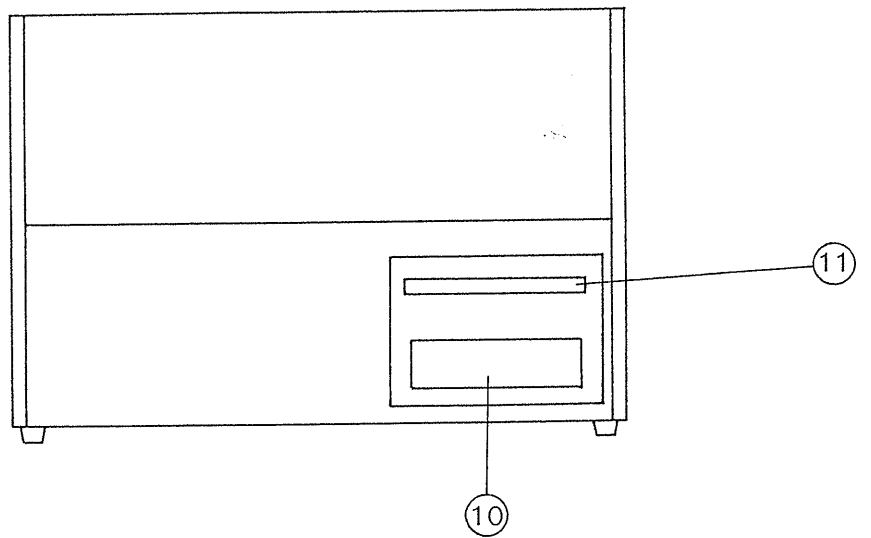

Fig. 3-2 Rear panel

### 3.2 Precaution

In using Model PAD 55-25, pay attention to the following:

( 1 ) Input power:

Ensure that the input power is  $100V \pm 10\%$  AC, 48~62 Hz, and that the power line has a sufficient capacity. ( See the characteristic curve illustrated at the end of this manual. )

( 2 ) Location:

The place of use must not be of the following conditions.

- o Exposed to heat radiation source.
- o Ambient temperature is within 0 to 40°C.
- o Atmosphere is highly humid and dusty.
- o The surface is not flat.

Note that heat radiation is impeded and the power supply may be damaged if it is used being laid on its side or an object is placed on its top.

When two or more power supplies are used being stacked or installed on a rack, provide a gap of 50 mm or more between two adjoining power supplies.

( 3 ) Output voltage setting knob:

The vernier-type potentiometer used to control the output voltage is an endless type. When the knob is rotated more than 5 turns, the rotation become heavy. This point signifies the end point of electrical adjustment.

( 4 ) Overshoot:

The output voltage of the power supply never exceeds the set voltage, even as transients when the input power is turned on and off.

( 5 ) Parallel operation:

When two ( or more ) power supplies are operated in parallel, a potential difference may be produced between chassis due to unbalance of the internal line filters. In such a case, connect together the GND terminals of the power supplies. The potential difference does not cause any damage or hazards.

### 3.3 How to use sampling terminals

When Model PAD 55-25 is far from the load, a long lead connecting the output terminals and the load causes load regulation to be deteriorated because of voltage drop due to load resistance.

The sampling terminals serve to solve this trouble.

For the connection diagram, see Fig. 3-3.

( 1 ) Disconnect the short bars from -SAMPLING, - and +, and +SAMPLING terminals on the front panel. Remove the jumpers between -S, - and +, and +S terminals on the rear terminal board ( 1 ).

( 2 ) Connect the output terminals on the rear or front panel to the load. Connect the sampling terminals and the nearest load terminals with other leads. Match the polarity of the sampling terminals to that of the output terminals.

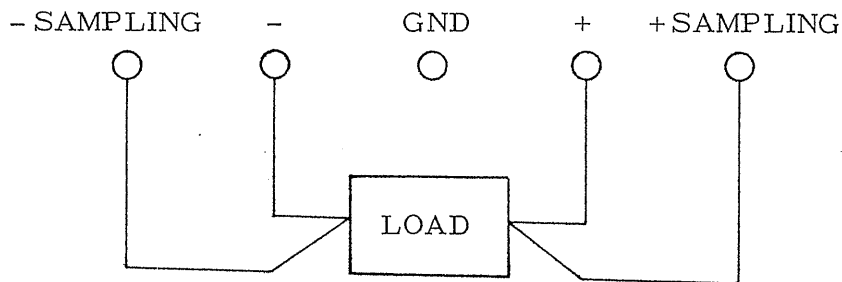

Fig. 3-3

Note 1: Deterioration of load regulation is calculated by the following formula:

$$V_d = I_o \times R \text{ ( m}\Omega \text{ )}$$

where  $I_o$  ( A ) = Load current

$R$  ( m $\Omega$  ) = Lead resistance

$V_d$  = Voltage drop

Note 2: Use two-conductor shielded wire for sampling to avoid induction causing ripple from outside. Check the sampling leads for proper polarity.

Note 3: Be careful since the lead connected to the load affects the preset constant current value due to its resistance.

Note 4: As long sampling leads tend to cause oscillation, connect electrolytic condenser with a capacitance of a few  $\mu$ F's with working voltage of 63V or more to sampling terminals in the proper polarity.

Note 5: Sampling is impossible if voltage drop of the lead connected to the load is 0.3V or more.

### 3.4 Constant-voltage, constant-current characteristics

The working output characteristic of Model PAD 55-25, called constant-voltage / constant-current automatic crossover type, permits continuous transition from constant-current to constant-voltage operation mode in response to the load change.

The intersection of constant-voltage and constant-current operation modes is called crossover point. Fig. 3-4 shows the relationship between this point and the load.

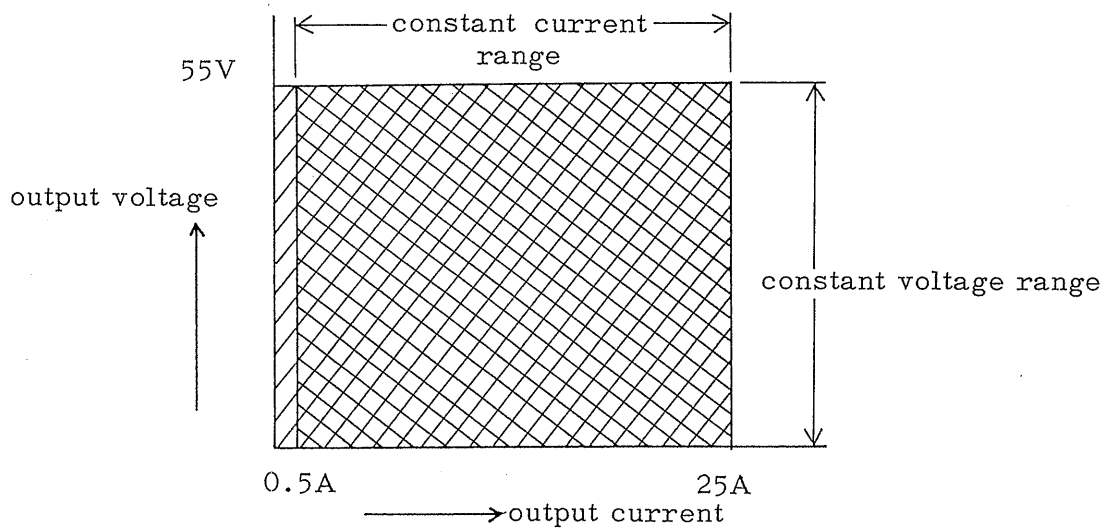

Fig. 3-4

The operation modes of PAD 55-25 are indicated by the area with oblique lines. Operation is possible anywhere within this area.

### 3.5 Transient response

Designed to meet a transient response quickly enough, PAD 55-25 can be used for digital or other circuits involving a drastic load variation and in which performance is affected by a transient variation. But this is the characteristic at the output terminals, and if a long lead is extended to the load, then influence of the inductance is not negligible. In such a case, use capacitors to cancel the inductance.

### 3.6 Single operation

#### Constant voltage performance

- 1 ) Connect the power cord. Throw the power switch upwards, and Model PAD 55-25 is ready to operate immediately, lighting the pilot lamp simultaneously.
- 2 ) Turn CURRENT knob fully clockwise. Turn VOLTAGE knob until the desired voltage is obtained. ( Clockwise rotation increases the output voltage. )
- 3 ) Connect the output terminals to the load.

Note: When requiring limiting the load current to a certain value. Before the load connect, short the output terminals. Set " CURRENT " knob to be desired current value.

#### Constant current performance

- 1 ) The same as Paragraph ( 1 ) in "Constant voltage performance" above.
- 2 ) Turn " VOLTAGE " knob clockwise until its motion becomes slightly rough. ( This implies the maximum output voltage. )

- 3 ) Short the output terminals. Turn "CURRENT" knob until the desired current value is obtained. ( Clockwise rotation increases the output current. )
- 4 ) The same as Paragraph 3 in "Constant voltage performance" above.

Note 1: Model PAD 55-25 is a constant voltage-current automatic crossover type. When the load current is smaller, the constant current mode is changed over to the constant voltage mode at a specific voltage. Thus, when requiring limiting the output voltage to a certain value, preset the output voltage to the desired value.

Note 2: The constant voltage or constant current mode is indicated by the respective lamps on the front panel alternately.

Constant current mode lamp .....C.C.

Constant voltage mode lamp .....C.V.

Note 3: For use of the sampling terminals, see Note 3 in Chapter 3.4 "How to use sampling terminals".

### 3.7 Series connection

A higher output voltage than 55V can be obtained by connecting two Model PAD 55-25s in series.

Note 1: Be careful not to ground the positive terminal of one Model PAD 55-25 when grounding the negative terminal of the other in Fig. 3-5.

Note 2: The voltage at each output terminal should not exceed the floating voltage.

Note 3: Avoid the series connection with other model.

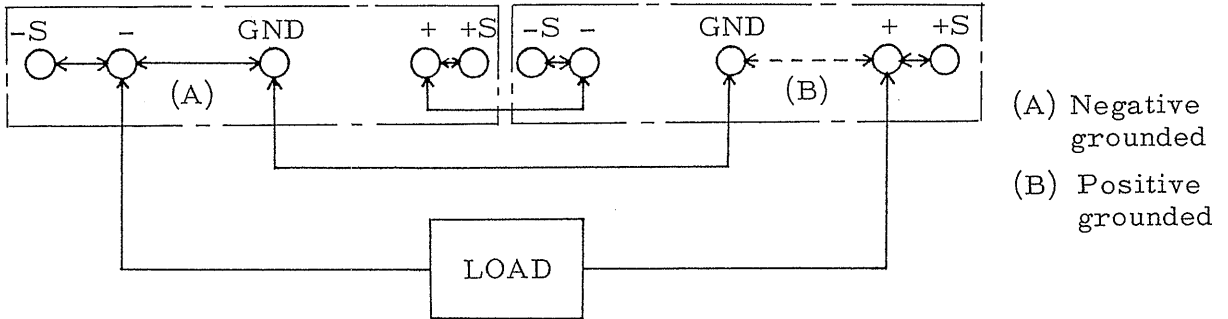

Fig. 3-5 Series connection diagram

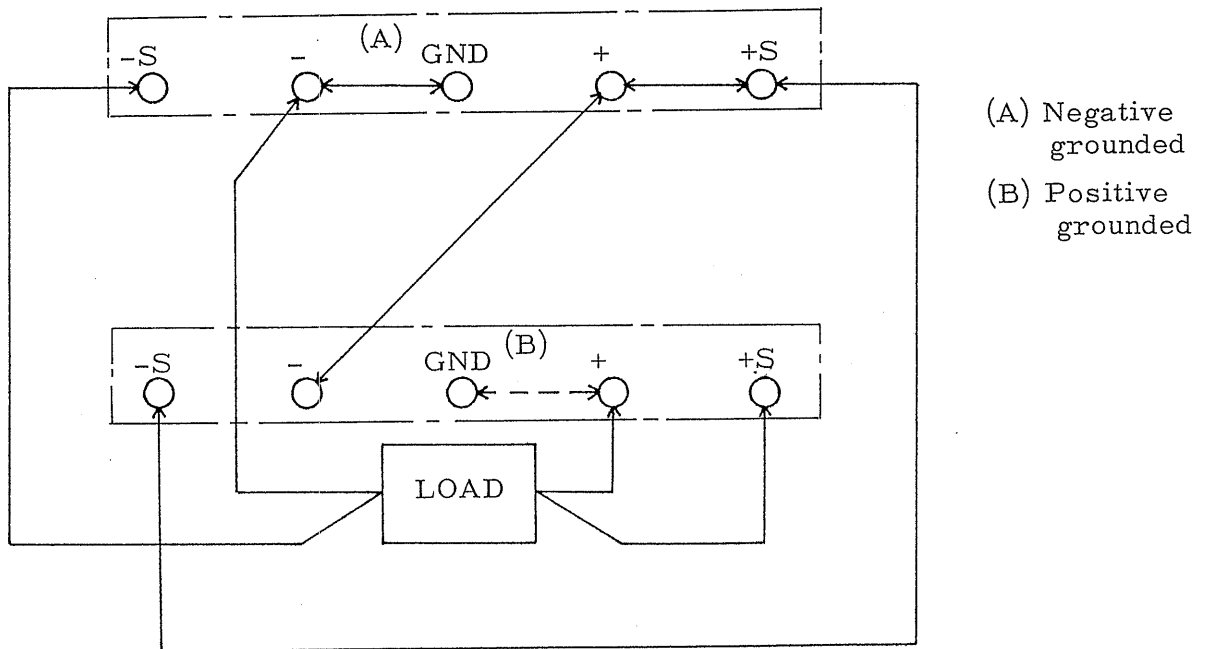

Fig. 3-6 Sampling terminal connection diagram in series connection



When two Model PAD 55-25 connected in series are overloaded, one Model PAD 55-25, which has been changed over to the constant current mode first, would be supplied with the output voltage of the other inversely. This would damage series transistors of the former. To avoid this trouble, a diode is connected between the output terminals of each Model PAD 55-25, as shown in Fig. 3-7.

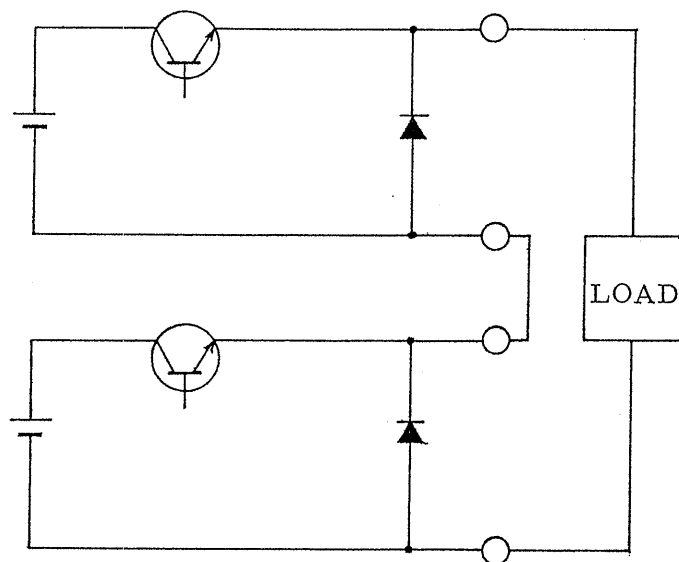

Fig. 3-7

### 3.8 Parallel connection

When a larger current than 25A is required, connect the output terminals of two Model PAD 55-25 in parallel.

- 1) Set the output voltage of the two Model PAD 55-25 in parallel connection at values as close as possible each other since a setting difference between the two would cause load fluctuation.
- 2) Turn "CURRENT" knobs fully clockwise.

- 3) Connect the output terminals of two Model PAD 55-25 to the load so that their polarity matches. The grounding polarity of both should also match.

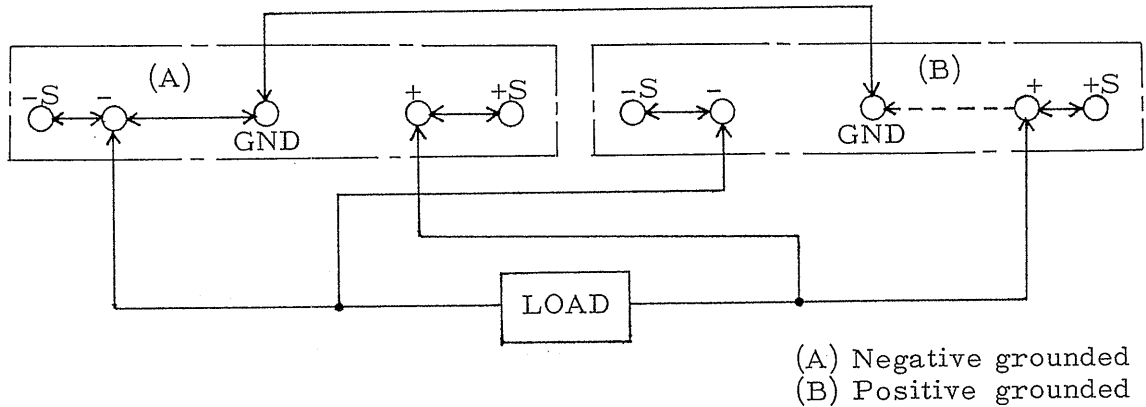

Fig. 3-8 Parallel connection diagrams

Voltage-current characteristics in parallel connection

As the voltage-current characteristics in parallel connection in Fig. 3-9 show the output voltage in parallel operation remains constant until one Model 55-25 with a higher output voltage is overloaded. When one Model PAD 55-25 is changed over to the constant current mode, the output voltage decreases until it reaches the value preset by the other Model PAD 55-25, whose output terminals are changed over from an inverse voltage condition to a normal one, causing the constant voltage mode. Thus, load fluctuation causes the output voltage to fluctuate by the preset output voltage difference  $\Delta V$  between the two units, and ripple characteristics are reduced.

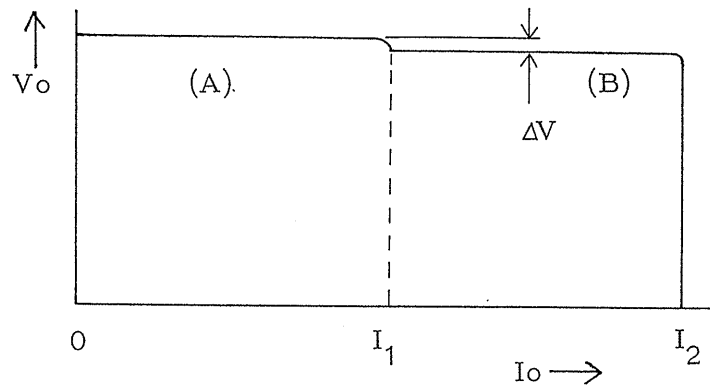

Fig. 3-9 Voltage-current characteristics diagram

### 3.9 One-control parallel operation

When a larger current than 25A is required, one-control parallel operation of two Model PAD 55-25 is preferable since the characteristics are improved largely, as compared with those in parallel connection.

In one-control parallel operation, one of the Model PAD 55-25 operates as the master unit, by which the output voltage is adjusted, and the other as the slave whose output voltage is controlled by the master unit.

- 1 ) Connect the terminals on the rear panel of the master to the slave and the load as shown in Fig. 3-10.
- 2 ) Pick up the output at the output terminals on the rear panel of the master. When turning on the power or output switches of the master and slave, start with the master. When turning them off, start with the slave.

Note 1: Picking up the output on the output terminals on the front panel of the master causes load regulation to be deteriorated somewhat, and current unbalance occurs between the master and slave.

Note 2: To prevent load regulation from increase, use the sampling terminals. ( Connection is showed Fig. 3-11.)

Note 3: Turn "VOLTAGE, CURRENT" knob of the slave fully clockwise.

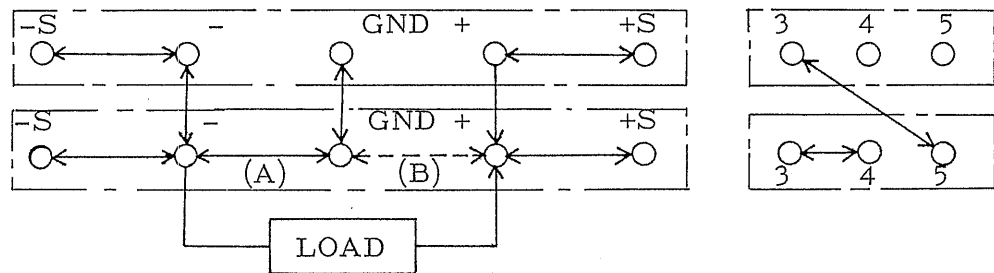

Fig. 3-10 One-control parallel operation master, slave,load

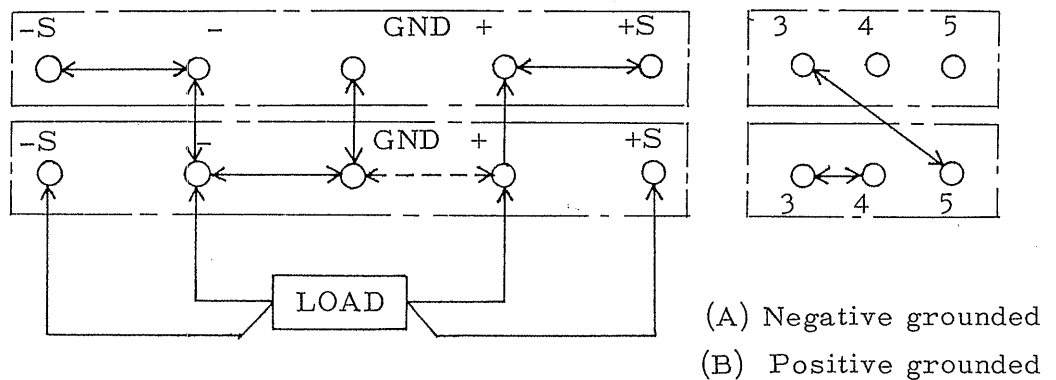

Fig. 3-11 Using sampling terminal in one-control parallel operation

### 3.10 Remote control

To vary output voltage by remote control, improve efficiency in varying output voltage and obtain the preset output voltages simply by operation of switches or others, use the remote control terminals on the rear panel.

- 1 ) Turn off power switch and remove jumpers from terminals (1) and (2) on the rear panel.
- 2 ) Provide a suitable variable element between (1) and  $-S$ .  
Note: Variable element will be described in detail later.
- 3 ) Turn on power switch and then output voltage will vary according to the characteristics of the variable element connected.

Note: If the line connected to variable element is open, output voltage cannot be controlled, and excessive output voltage is detected. Make the connection with power switched off.

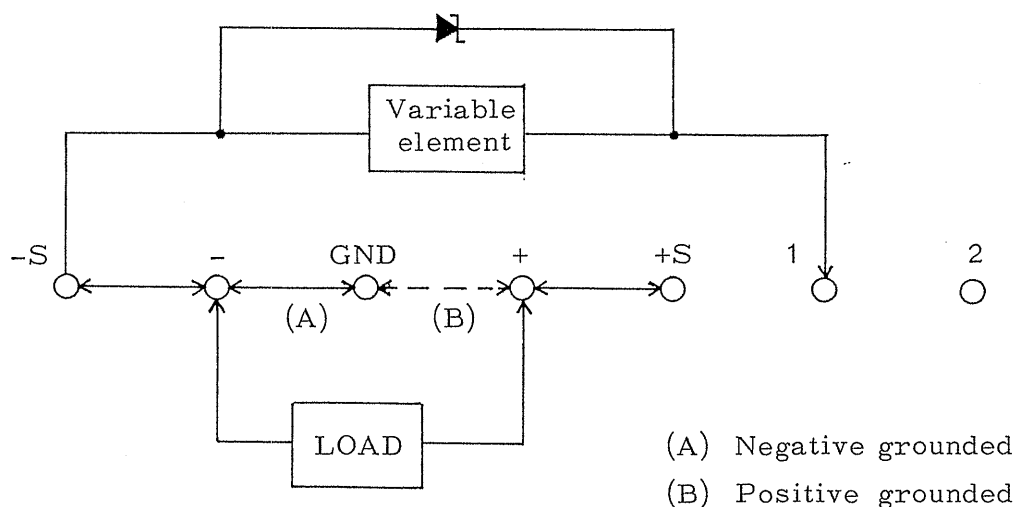

Fig. 3-12

3.10-1 To vary output voltage by remote control.

Output voltage varies at a rate of approximately 0.55V/kΩ with reference to the resistance of the resistor connected.

Therefore,

$$\text{Output voltage } V_o \text{ (V)} = \text{Voltage variation rate } 0.55\text{V/k}\Omega \times R_r \text{ (k}\Omega)$$

where voltage variation rate indicates voltage change for each 1kΩ, and  $R_r$  the resistance (kΩ) for remote control.

If no suitable resistor is available and output  $V_o$  may exceed the rated output or it is desired to fix voltage at a certain level, output voltage can be limited by connecting zener diode with a small leakage current to the resistor. ( See Fig. 3-12 )

Note 1: Use a wire wound type variable resistor with a low temperature coefficient or a metal-film one, and the power rating of such a resistor must be at least 0.5W more over. Otherwise, the temperature drift of output voltage may deteriorate.

Note 2: PAD 55-25 can operate steadily if the external lines connected are limited to approximately 2m. If longer lines are used, output voltage may become unstable.

3.10-2 To improve efficiency in varying output voltage ( to finally adjust voltage ).

As already mentioned, output voltage is proportional to the external resistance.

Letting  $V_{res}$  stand for the required efficiency, the efficiency of the resistor can be formulated as follows.

$$R_{res} = \frac{V_{res}}{\text{Voltage variation rate } 0.55\text{V/k}\Omega} \quad (\text{k}\Omega)$$

### 3.11 Internal temperature detector circuit

When the internal temperature exceeds preset limit, the built-in circuit automatically shuts off the output circuit. Therefore, if this instrument is used in a place where the ambient temperature is over  $40^{\circ}\text{C}$ , or used by mounting it on another instrument, the entire output current may not be obtained. Since this circuit is restored to its original condition soon after the internal temperature lowers below the specific value, turn off the power switch, and cool the instrument if the output cannot be obtained as specified while the circuits operate normally.

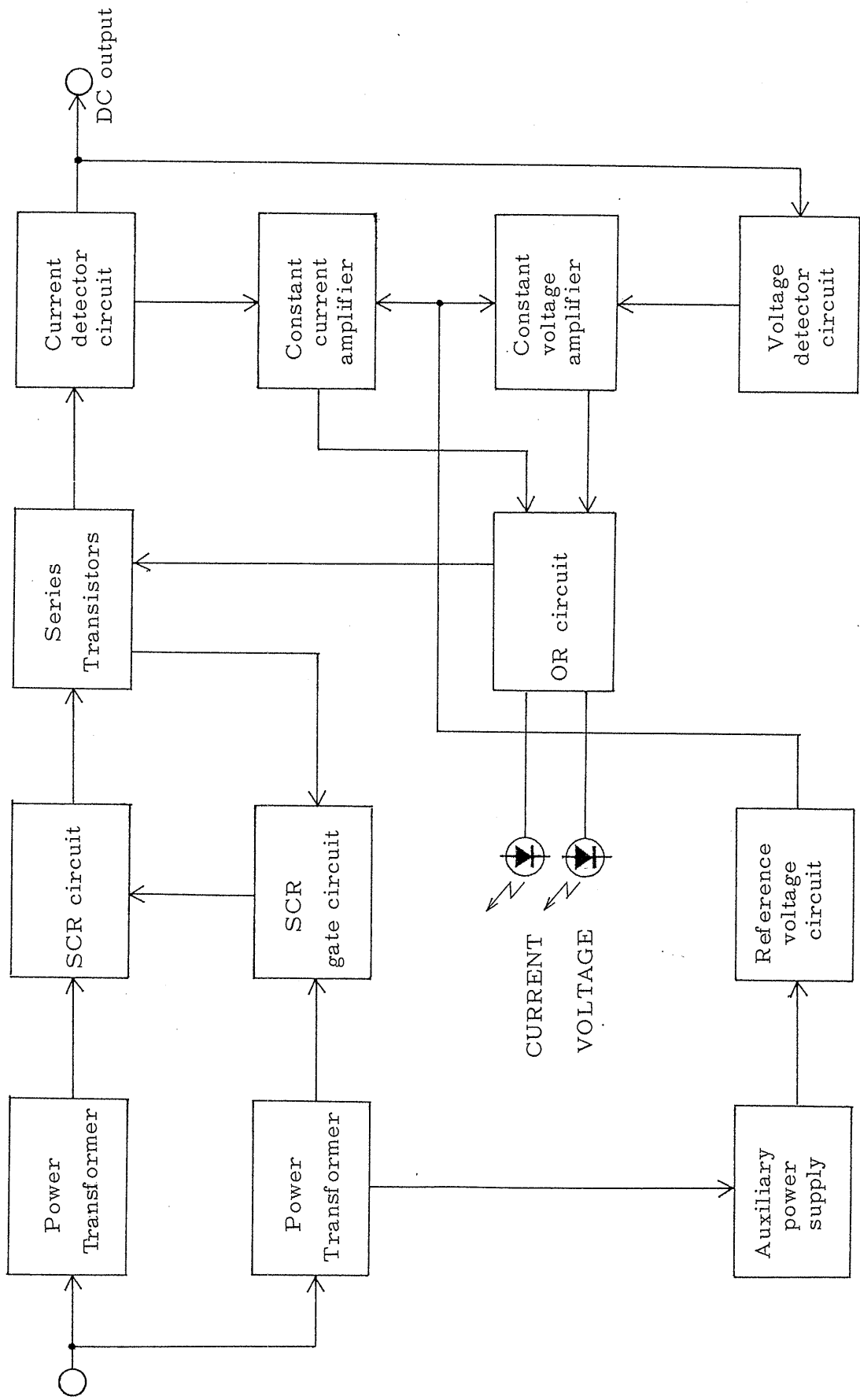
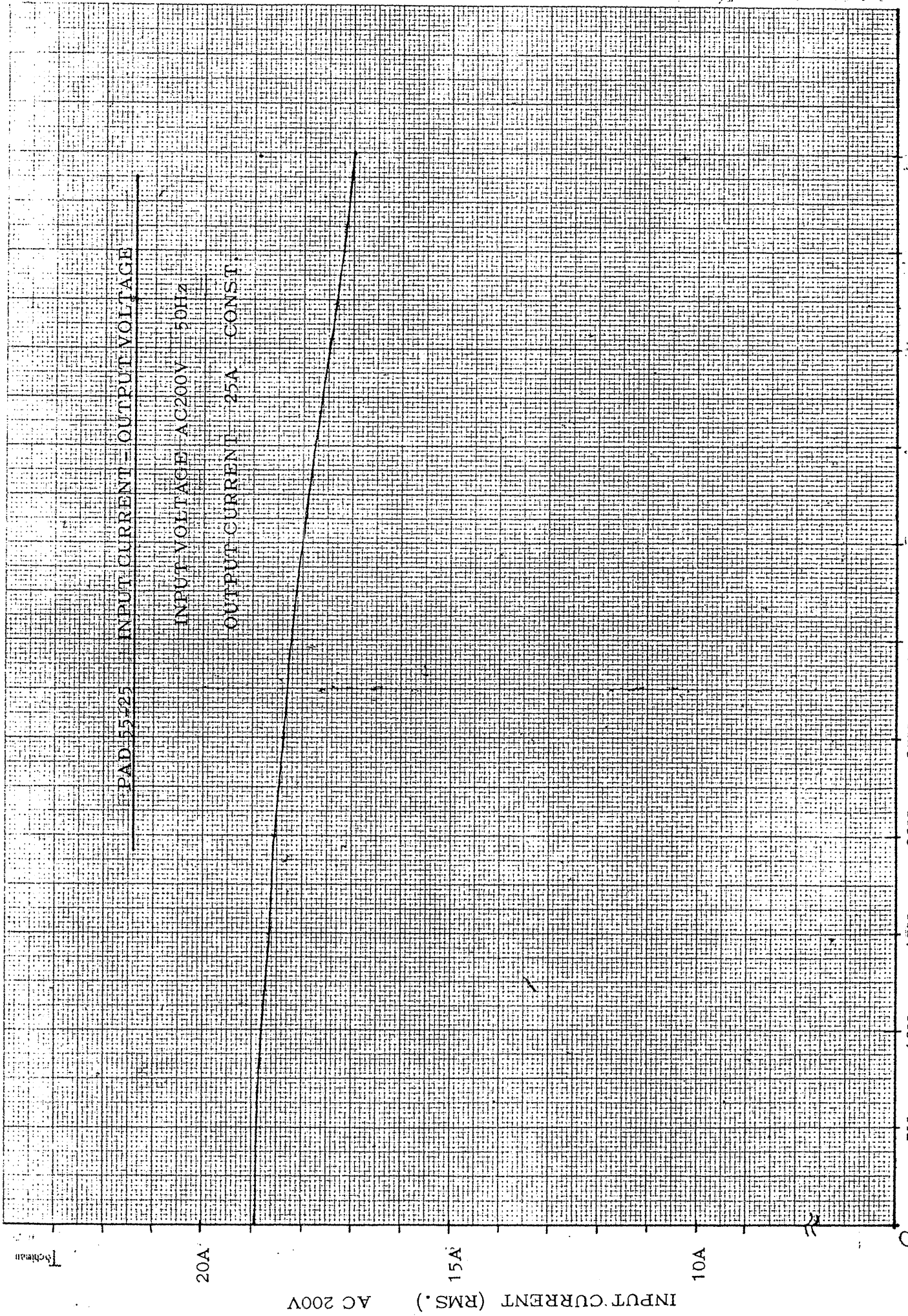

Fig. 4-1 Block diagram





Technical

20A

15A

10A

INPUT CURRENT (RMS.) AC 200V

0 5V 10V 15V 20V 25V 30V 35V 40V 45V 50V 55V

OUTPUT VOLTAGE